

# Extract Only Direct Driven Air Handling Unit

Packaged Air Handling for General Ventilation Applications

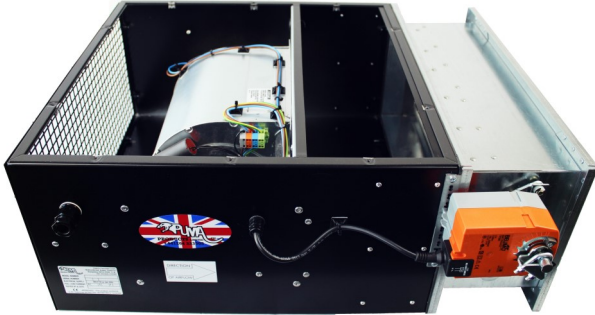

## Internal Duct Mounted Unit

- Monocoque Construction - Single Skin
- Channel & Tray Construction - Double Skin
- Ral 9005 Satin Black Powdercoat Finish
- Top or Bottom Access Lid
- Vertical / Through-wall / Ceiling Mounting
- Internal flange duct connections
- Fully Sealed 2Hr Fire/Smoke Damper

## Options and Accessories available on request

### Weatherproof Roof Mounted Unit

- Channel & Tray Construction
- Single Skin Only
- Ral 5017 Mid Blue Powdercoat Finish
- Top Access Pitched Lid
- Weather cowl on Discharge
- Ducted Both Ends version available
- External flange duct connection



**Permanent Extract** (denoted **PE**) models are used for general extract ventilation.

The Puma range of extract units are fitted with a double inlet Direct Driven centrifugal fan c/w integral single or three phase motor.

The Channel & Tray (CT) construction is available as single skin (SSK) lined with 25mm Pyrosorb thermal insulation. Or Double Skin (DSK) (25mm thick) filled with Rockwool insulation. Controls include terminal block, mains isolator, fan fuse and Volt Free Contacts for airflow indication.

*Improve your Environment with*



# Performance Data

Model Number	Duty in m3/sec @ given External Static Pressure (Pa)											
	0	50	75	100	125	150	200	250	300	350	400	450
200/200	0.1	0.09	0.08	0.08	0.07	0.07	0.06	0.05	0.01	-	-	-
200/250	0.12	0.11	0.1	0.095	0.09	0.085	0.08	0.07	0.06	-	-	-
200/300	0.15	0.14	0.13	0.125	0.12	0.11	0.1	0.09	0.085	0.06	-	-
250/400	0.2	0.2	0.18	0.17	0.16	0.15	0.13	0.1	0.07	-	-	-
250/600	0.27	0.26	0.25	0.24	0.23	0.22	0.21	0.19	0.17	-	-	-
300/1400	0.65	0.64	0.63	0.61	0.6	0.59	0.58	0.55	0.53	0.51	0.49	0.46
350/850	0.42	0.4	0.39	0.37	0.33	0.3	0.23	0.1	-	-	-	-
350/1000	0.53	0.48	0.43	0.4	0.38	0.31	0.24	0.1	-	-	-	-
350/1200	0.59	0.57	0.56	0.55	0.55	0.54	0.49	0.41	0.25	0.01	-	-
400/1800	0.95	0.9	0.89	0.89	0.89	0.88	0.83	0.81	0.76	0.68	-	-
450/2500	1.27	1.2	1.1	1.07	1.03	0.97	0.89	0.84	0.72	0.55	-	-
550/3600	1.8	1.72	1.6	1.55	1.5	1.43	1.35	1.15	0.89	-	-	-
550/3700	1.79	1.75	1.72	1.68	1.66	1.58	1.51	1.42	1.36	1.3	1.16	0.86
550/4500	2.1	2.05	1.92	1.85	1.8	1.7	1.6	1.25	1.0	-	-	-

For higher performances please ask about our **PENTAPOST BELT DRIVEN** Range

### Typical Part Code:

W PE 250 / 400 - CM

Weatherproof \_\_\_\_\_

Permanent Extract \_\_\_\_\_

Unit Size \_\_\_\_\_

\_\_\_\_\_ Ceiling Mounted

\_\_\_\_\_ Fan & Motor Size

*Over 30 years supplying the  
Ventilation and Air Conditioning  
Industry*



# Electrical and Sound Data

Model Number	Motor Running Current (Amps)	Motor Starting Current (Amps)	Motor Power (Watts)	Induct Sound Power Levels dBW @ Octave Band Mid Frequency HZ								Breakout Noise Level dBA*	
				63	125	250	500	1K	2K	4K	8K	SSK	DSK
200/200	0.3	0.75	67	32	34	46	55	56	54	51	50	40	25
200/250	0.44	1.1	99	25	29	38	43	39	40	34	26	36	21
200/300	0.8	2.0	175	63	57	55	54	54	47	41	32	44	29
250/400	0.8	2.0	190	40	44	46	52	52	50	45	41	41	26
250/600	1.2	3.0	273	68	62	61	61	59	54	47	37	48	33
300/1400	7.6	19.0	1000	93	91	84	82	79	75	67	60	65	50
350/850	1.9	4.75	184	67	69	70	69	66	62	59	54	44	29
350/1000	2.3	5.75	300	71	72	73	72	70	66	62	57	48	33
350/1200	2.6	6.5	420	75	72	67	63	61	60	58	54	50	35
400/1800	4.2	12.5	550	76	74	66	64	60	57	49	41	53	38
450/2500	6.8	17.5	550	80	78	70	68	64	61	53	45	61	46
550/3600	4.3**	21.5**	1100	87	84	82	81	79	75	67	55	64	49
550/3700	4.7**	23.5**	1500	87	88	89	88	86	82	78	73	71	56
550/4500	4.5**	22.5**	1100	79	76	74	72	67	64	58	48	62	47

\* The dBA quoted is the mean 'A' weighted sound pressure level measured at a distance of 3m. It is included for comparative

purposes only and the actual sound level experienced will depend on the acoustic characteristics of the area being served. Ductwork and Silencers also have a major influence on breakout noise and actual noise levels in the system.

\*\* 380/415 V ac Three Phase Motor

## Options and Accessories

- SSK** Single Skin
- DSK** Double Skin (25mm Insulated Panels)
- FSD** Fire / Smoke Damper & Motor
- TD** Telescopic Duct
- WL** Weather Louvre
- SIL** Silencer

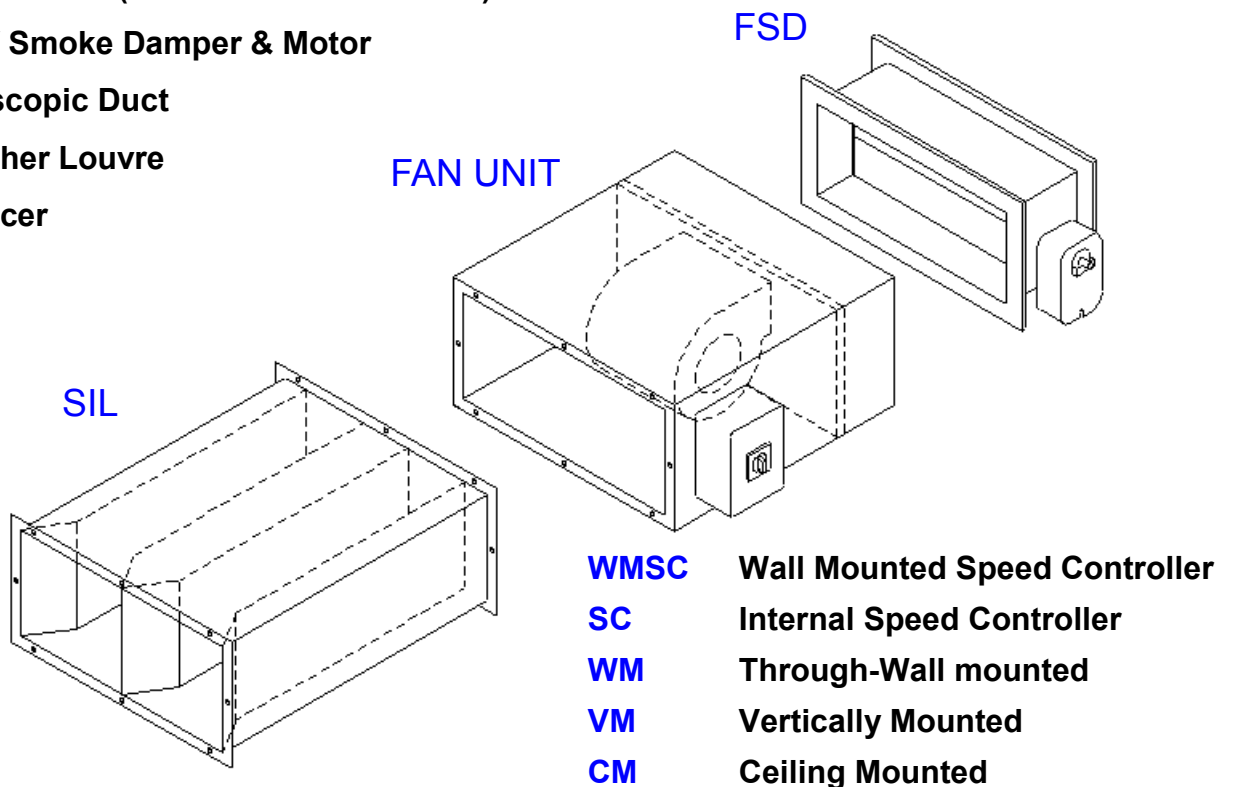

- WMSC** Wall Mounted Speed Controller
- SC** Internal Speed Controller
- WM** Through-Wall mounted
- VM** Vertically Mounted
- CM** Ceiling Mounted

# Dimensional Data

## Internal Duct Mounted Unit – FE or PE

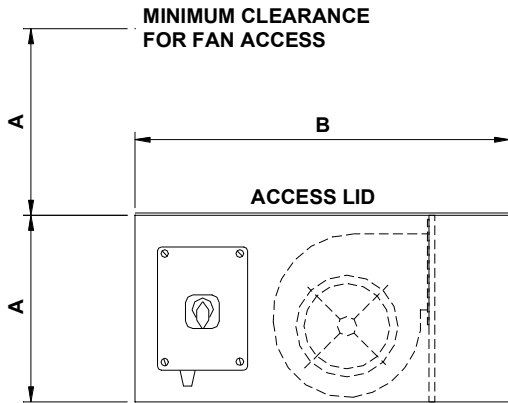

**SIDE VIEW**

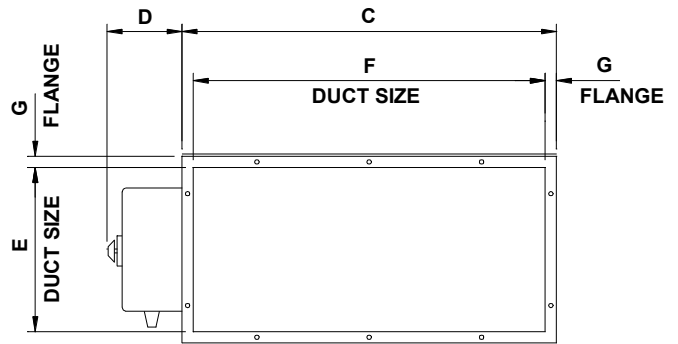

**END VIEW (DISCHARGE)**

## Weatherproof Roof Mounted Unit – WFE or WPE

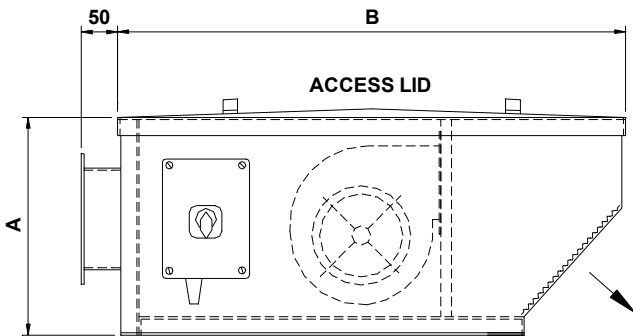

**SIDE VIEW**

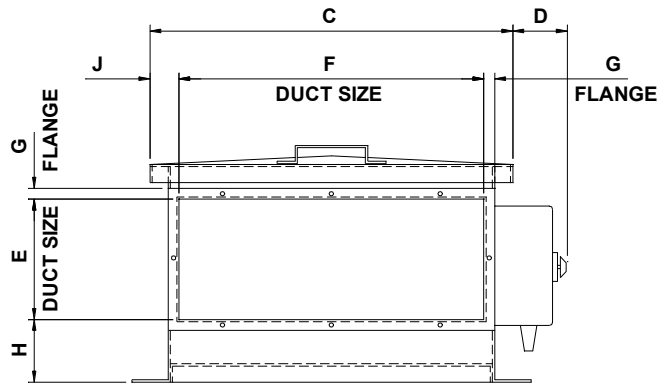

**END VIEW (INTAKE)**

Model Number	Dimensions In Millimetres											
	A		B	C		D*	E	F	G	H	J	WEIGHT
	SSK	DSK		SSK	DSK							
PE 200/ -	200	250	450	450	500	100	166	420	15	-	-	20 Kg
PE 250/ -	250	300	500	500	550	100	220	470	15	-	-	25 Kg
PE 300/ -	300	350	600	500	550	100	260	460	20	-	-	30 Kg
PE 350/ -	350	400	700	600	650	175	310	560	20	-	-	40 Kg
PE 400/ -	415	465	700	600	650	175	375	560	20	-	-	50 Kg
PE 450/ -	450	500	700	700	750	175	410	660	20	-	-	60 Kg
PE 550/ -	550	600	900	800	850	175	500	750	25	-	-	90 Kg
WPE 200/ -	225	-	650	500	-	75	126	314	13	50	93	25 Kg
WPE 250/ -	300	-	750	500	-	75	166	420	15	86	40	35 Kg
WPE 300/ -	350	-	800	600	-	75	166	420	15	125	90	40 Kg
WPE 350/ -	400	-	850	700	-	75	220	470	15	135	115	45 Kg
WPE 400/ -	450	-	950	800	-	150	260	460	20	155	170	60 Kg
WPE 450/ -	500	-	1000	800	-	150	310	560	20	120	120	70 Kg
WPE 550/ -	600	-	1150	1000	-	150	375	560	20	195	220	100 Kg

Unit 6, Viscount Court, Walworth Business Park, Andover,

Hampshire SP10 5NW England

[www.pumaproducts.co.uk](http://www.pumaproducts.co.uk)

Telephone: +44 (0) 1264 333305

Facsimile: +44 (0) 1264 333310

Email: [sales@pumaproducts.co.uk](mailto:sales@pumaproducts.co.uk)



ISO 9001:2008

Certificate Number: 1206 Issue:01

